

# Outgassing Compliant Air Core Inductors

AE466RAS  
AE522RAS



- Excellent Q factors – up to 230 at 400 MHz!
- Current handling as high as 5.7 Amps
- Inductance values from 47 to 300 nH
- Flat top and bottom for reliable pick and place and mechanical stability
- High temperature materials allow operation in ambient temperatures up to 155°C.
- Passes NASA low outgassing specifications
- Tin-lead (Sn-Pb) terminations ensure the best possible board adhesion

**Terminations** Tin-lead (63/37) over copper. Other terminations also available.

**Ambient temperature** –55°C to +155°C with Irms current

**Maximum part temperature** +155°C (ambient + temp rise).

**Storage temperature** Component: –55°C to +155°C.

Tape and reel packaging: –55°C to +80°C

**Resistance to soldering heat** Max three 40 second reflows at +260°C, parts cooled to room temperature between cycles

**Temperature Coefficient of Inductance (TCL)** +5 to +70 ppm/°C

**Moisture Sensitivity Level (MSL)** 1 (unlimited floor life at <30°C / 85% relative humidity)

Part number <sup>1</sup>	Inductance <sup>2</sup> (nH)	Percent tolerance	Q <sup>3</sup>		Test frequency (MHz)	SRF min <sup>4</sup> (GHz)	DCR max (mOhm)	Irms <sup>5</sup> (A)
			min	typ				
AE466RAS47N_SZ	47	5,2	190	230	400	1.40	6.35	4.9
AE466RAS68N_SZ	68	5,2	190	230	400	1.30	8.60	5.5
AE466RAS82N_SZ	82	5,2	190	230	400	1.20	9.40	5.6
AE522RAS90N_SZ	90	5,2	120	140	50	0.900	5.50	5.0
AE522RAS111_SZ	110	5,2	120	140	50	0.850	6.50	5.7
AE522RAS131_SZ	130	5,2	120	140	50	0.800	7.50	5.4
AE522RAS161_SZ	160	5,2	120	140	50	0.750	8.25	5.7
AE522RAS181_SZ	180	5,2	120	140	50	0.750	9.50	5.0
AE522RAS221_SZ	220	5,2	120	140	50	0.900	11.0	5.0
AE522RAS271_SZ	270	5,2	120	140	50	0.800	12.5	4.3
AE522RAS301_SZ	300	5,2	130	150	50	0.720	13.8	3.7

1. When ordering, specify **tolerance, termination and testing** codes:

AE522RAS301JSZ

**Tolerance:** G = 2% J = 5%

**Termination:** S = Tin-lead (63/37) over copper  
T = Tin-silver-copper (95.5/4/0.5) over copper  
L = Tin-silver (96.5/3.5) over copper

**Testing:** Z = Unscreened  
H = Group A screening per Coilcraft CP-SA-10001  
T = Screening per MIL-STD-981  
U = Screening per EEE-INST-002  
F = Screening per ESCC 3201  
All screening performed to the document's latest revision

2. Inductance measured at specified test frequency, 0.1 Vrms, 0 A using an Agilent/HP 4287A LCR meter with the following Coilcraft test fixtures: CCF1191C for AE466RAS; CCF1197A for AE522RAS.

3. Q measured at specified test frequency, using an Agilent/HP 4291A impedance analyzer.

4. SRF measured using an Agilent/HP 8753 network analyzer and the following Coilcraft test fixtures: CCF1143 for AE466RAS; CCF1199 for AE522RAS90N and AE522RAS161; CCF1200 for others.

5. Current that causes a 20°C temperature rise from 25°C ambient. This information is for reference only and does not represent absolute maximum ratings.

6. Electrical specifications at 25°C.

Refer to Doc 362 "Soldering Surface Mount Components" before soldering.

**Coilcraft CPS**

CRITICAL PRODUCTS & SERVICES

© Coilcraft, Inc. 2017

1102 Silver Lake Road  
Cary, IL 60013  
Phone 800-981-0363

Fax 847-639-1508  
Email cps@coilcraft.com  
www.coilcraft-cps.com

Document AE720-1 Revised 05/18/17

This product may not be used in medical or high risk applications without prior Coilcraft approval. Specifications subject to change without notice. Please check our web site for latest information.

# Square Air Core Inductors – AE466RAS, AE522RAS

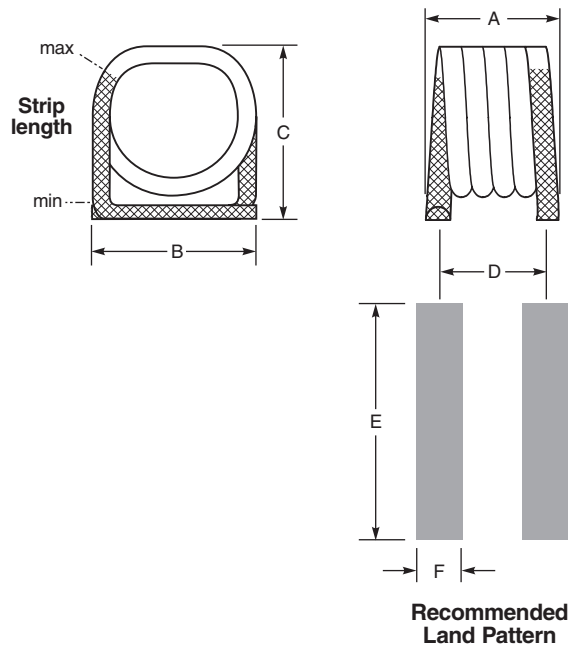

Part number	A	B	C	D	E	F	Weight ±20% (mg)
AE466RAS47N	0.160±0.010 4,06 ±0,254	0.140 ±0.007 3,56 ±0,178	0.147 ±0.007 3,73 ±0,178	0.140 3,56	0.175 4,45	0.070 1,78	110
AE466RAS68N	0.210 ±0.010 5,33 ±0,254	0.140 ±0.007 3,56 ±0,178	0.147 ±0.007 3,73 ±0,178	0.190 4,83	0.175 4,45	0.070 1,78	145
AE466RAS82N	0.230 ±0.010 5,84 ±0,254	0.140 ±0.007 3,56 ±0,178	0.147 ±0.007 3,73 ±0,178	0.210 5,33	0.175 4,45	0.070 1,78	165
AE522RAS90N	0.205 ±0.015 5,21 ±0,381	0.215 ±0.010 5,46 ±0,254	0.224 ±0.010 5,69 ±0,254	0.175 4,45	0.255 6,48	0.085 2,16	280
AE522RAS111	0.250 ±0.015 6,35 ±0,381	0.220±0.010 5,59 ±0,254	0.224 ±0.010 5,69 ±0,254	0.230 5,84	0.265 6,73	0.085 2,16	330
AE522RAS131	0.265 ±0.015 6,73 ±0,381	0.220 ±0.010 5,59 ±0,254	0.224 ±0.010 5,69 ±0,254	0.245 6,22	0.265 6,73	0.085 2,16	371
AE522RAS161	0.290 ±0.015 7,37 ±0,381	0.220 ±0.010 5,59 ±0,254	0.224 ±0.010 5,69 ±0,254	0.260 6,60	0.265 6,73	0.085 2,16	425
AE522RAS181	0.320 ±0.015 8,13 ±0,381	0.220 ±0.010 5,59 ±0,254	0.224 ±0.010 5,69 ±0,254	0.290 7,37	0.265 6,73	0.085 2,16	460
AE522RAS221	0.390 ±0.015 9,91 ±0,381	0.220 ±0.010 5,59 ±0,254	0.224 ±0.010 5,69 ±0,254	0.360 9,14	0.265 6,73	0.085 2,16	550
AE522RAS271	0.460 ±0.015 11,68 ±0,381	0.220 ±0.010 5,59 ±0,254	0.224 ±0.010 5,69 ±0,254	0.420 10,67	0.265 6,73	0.085 2,16	640
AE522RAS301	0.470 ±0.015 11,94 ±0,381	0.225 ±0.010 5,72 ±0,254	0.224 ±0.010 5,69 ±0,254	0.440 11,18	0.265 6,73	0.085 2,16	650

All dimensions are in  $\frac{\text{inches}}{\text{mm}}$ .

## Packaging:

**AE466RAS47N** 500/7" reel; 2000/13" reel Plastic tape: 12 mm wide, 0.26 mm thick, 8 mm pocket spacing, 4.06 mm pocket depth

**AE466RAS68N** 500/7" reel; 2000/13" reel Plastic tape: 12 mm wide, 0.26 mm thick, 8 mm pocket spacing, 4.06 mm pocket depth

**AE466RAS82N** 500/7" reel; 2000/13" reel Plastic tape: 12 mm wide, 0.26 mm thick, 8 mm pocket spacing, 4.06 mm pocket depth

**AE522RAS90N** 250/7" reel; 750/13" reel Plastic tape: 16 mm wide, 0.32 mm thick, 12 mm pocket spacing, 5.97 mm pocket depth

**AE522RAS111** 250/7" reel; 750/13" reel Plastic tape: 16 mm wide, 0.40 mm thick, 12 mm pocket spacing, 6.10 mm pocket depth

**AE522RAS131** 250/7" reel; 750/13" reel Plastic tape: 16 mm wide, 0.40 mm thick, 12 mm pocket spacing, 6.10 mm pocket depth

**AE522RAS161** 250/7" reel; 750/13" reel Plastic tape: 16 mm wide, 0.33 mm thick, 12 mm pocket spacing, 5.97 mm pocket depth

**AE522RAS181** 250/7" reel; 750/13" reel Plastic tape: 16 mm wide, 0.40 mm thick, 12 mm pocket spacing, 6.10 mm pocket depth

**AE522RAS221** 250/7" reel; 750/13" reel Plastic tape: 24 mm wide, 0.40 mm thick, 12 mm pocket spacing, 6.10 mm pocket depth

**AE522RAS271** 250/7" reel; 750/13" reel Plastic tape: 24 mm wide, 0.40 mm thick, 12 mm pocket spacing, 6.10 mm pocket depth

**AE522RAS301** 250/7" reel; 750/13" reel Plastic tape: 24 mm wide, 0.33 mm thick, 12 mm pocket spacing, 5.97 mm pocket depth

## Recommended pick and place nozzles

**AE466RAS:** OD: 0.170 inch; ID: 0.059 inch

**AE522RAS, 47 – 200 nH:** 3.5 mm × 7 mm (rubber). This nozzle is available [here](#).

**AE522RAS, 270 – 300 nH:** 4.0 mm × 12 mm (rubber). This nozzle is available [here](#).

## S-Parameter files

ON OUR WEB SITE

## SPICE models

ON OUR WEB SITE



CRITICAL PRODUCTS & SERVICES

© Coilcraft, Inc. 2017

1102 Silver Lake Road  
Cary, IL 60013  
Phone 800-981-0363

Fax 847-639-1508  
Email [cps@coilcraft.com](mailto:cps@coilcraft.com)  
[www.coilcraft-cps.com](http://www.coilcraft-cps.com)

Document AE720-2 Revised 05/18/17

This product may not be used in medical or high risk applications without prior Coilcraft approval. Specifications subject to change without notice. Please check our web site for latest information.

# Square Air Core Inductors – AE466RAS, AE522RAS

## Typical Q vs Frequency

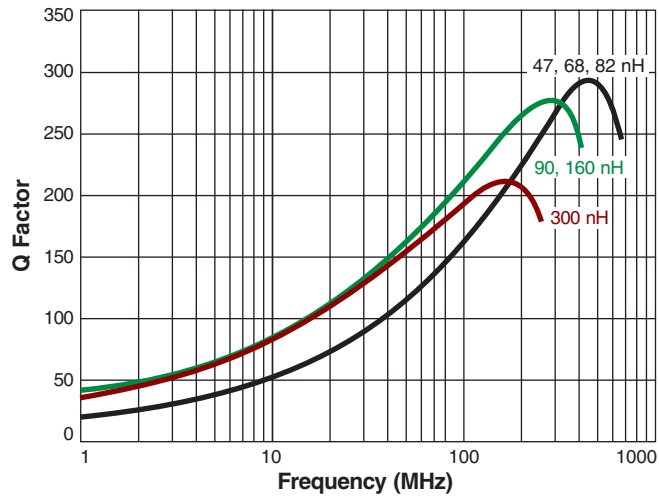

## Typical L vs Frequency

